

# HYDRAULIC TORQUE WRENCH

## HEX DRIVE HYDRAULIC TORQUE WRENCH

### TPS – TH Hydraulic Torque Wrench

### TH – SERIES



The material of the Hydraulic Torque Wrench is Aluminum Titanium Alloy and super high strength alloy steel for increased strength and durability of the tool. High repeatability with a precise accuracy of +/- 3%

The 360° x 180° uni-swivel allows ease of use in confined spaces and eliminates hose kinking. It is unbeaten for durability and accuracy.

Quick change ratchet link and anti-lock drive pawl





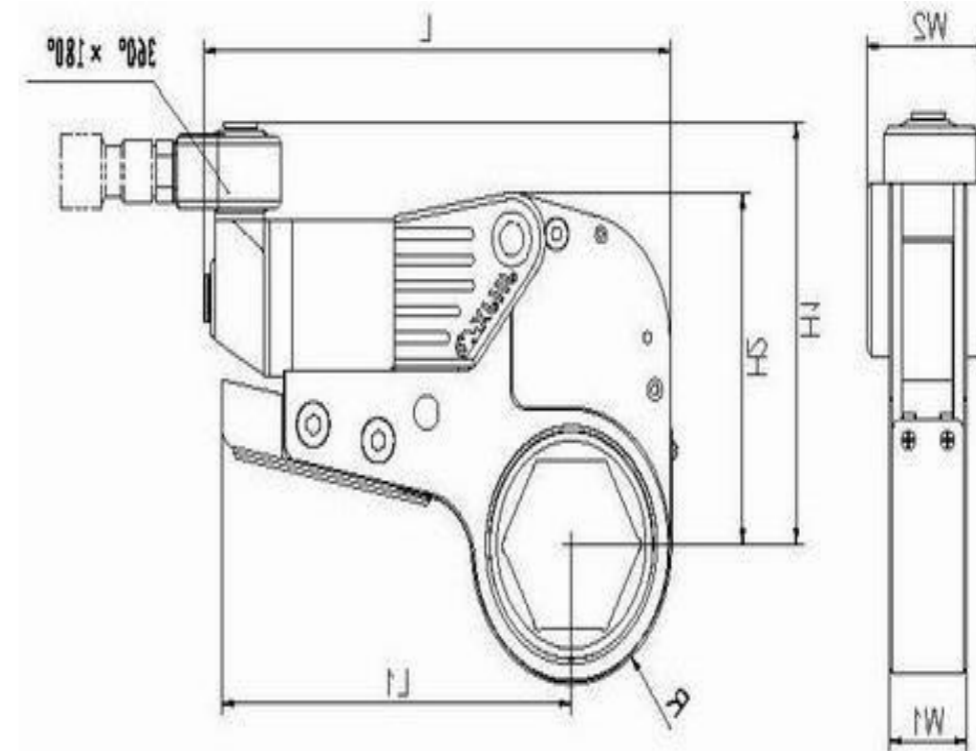

### TH - Series Models Technical Data Sheet and Dimensions

	TH - 2	TH - 4	TH - 8	TH - 13	TH - 16	TH - 30
Torque Max (ft.lb)	1842	3921	7602	13034	16654	28788
Torque Min (ft.lb)	177	355	740	1254	1634	2740
Nut Size (MM)	27-50	27-65	50-90	85-115	95-135	100-155
L (mm)	205	251.3	302.5	367	400.5	457.5
L1 (mm)	147	188	233	283	308	364
H1 (mm)	129	163	191	223	246	282
H2 (mm)	100	136	166.5	198	224	265
W1 (mm)	32	41	53	64	70	84
W2 (mm)	50	66	83	99	110	132
R (mm)	41.3	53.8	68.8	85.3	98.8	115.8
Weight (kg)	2.2	5	9.6	16.9	22.9	38



### APPLICATIONS

-   
Gas and Oil
-   
Petrochemical
-   
WINDMILL
-   
MINING